

8 BW4-CTM-P-F (CE / UL)

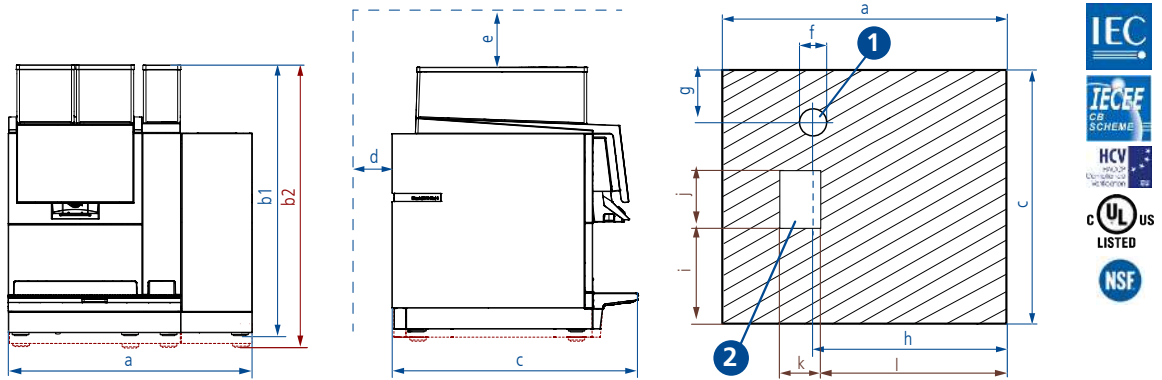

- 1 Hole diameter 70 mm / 2.75 in for water / milk inlet / water drain / sensor cable / power cable etc.
- 2 Cut-out for grounds ejection

a	580 mm / 22.83 in	c	600 mm / 23.62 in	f	70 mm / 2.75 in	i	213 mm / 8.38 in
b1	CE: 646 mm / 25.43 in (feet: 57 mm / 2.24 in) or optionally 676 mm / 26.61 in (feet: 87 mm / 3.42 in)	d	50 mm / 1.96 in	g	150 mm / 5.9 in	j	106 mm / 4.17 in
b2	UL: 676 mm / 26.61 in (feet: 87 mm / 3.42 in)	e	350 mm / 13.77 in	h	420 mm / 16.53 in	k	63 mm / 2.48 in
						l	406 mm / 15.08 in

Drain

- m: Distance of machine to drain < 1 m / 39.37 in.
- Drain line (hose) not sagging.
- No back pressure in the water line.
- The end of the line not submerged in water.

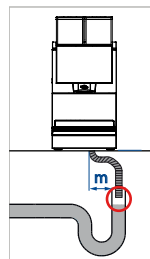

Refrigerator milk suction hose

- Max. length of refrigerator milk suction hose = 1200 mm / 47.24 in or 2200 mm / 86.6 in.
- Position the refrigerator close enough to the coffee machine.

Machine parameters		Water connection specifications		
Connection / power CE	Machine with single phase (limited performance):	220-240 VAC / 50-60 Hz 3100-3700 W / 16 A 220-240 VAC / 50-60 Hz 2700-3100 W / 13 A	Water supply	3/8"
	Machine with single phase:	220-240 VAC / 50-60 Hz 5800-7100 W / 32 A	Dynamic water pressure	2-4 bar 30-60 psi
	Machine with three phases:	380-415 VAC / 50-60 Hz 5800-7100 W / 3 x 16 A	Water boiler pressure	11.7 bar 169.6 psi
Connection / power UL		208 VAC / 60 Hz 5700 W / 27 A	Steam boiler pressure	2.6 bar 37.7 psi
Outlet height	85-172 mm (manual) / 96-192 mm (automatic) 3.34-6.77 in (manual) / 3.77-7.55 in (automatic)		Chlorine TDS	None 70-200 ppm
Weight	85 kg / 187.39 lbs		Total hardness	5-8 °dH / 8-14 °fH
			pH	6.8-7.4
			Alkalinity	<100 ppm <0.25 ppm
			Iron	