

3 BW4c-CTM-P

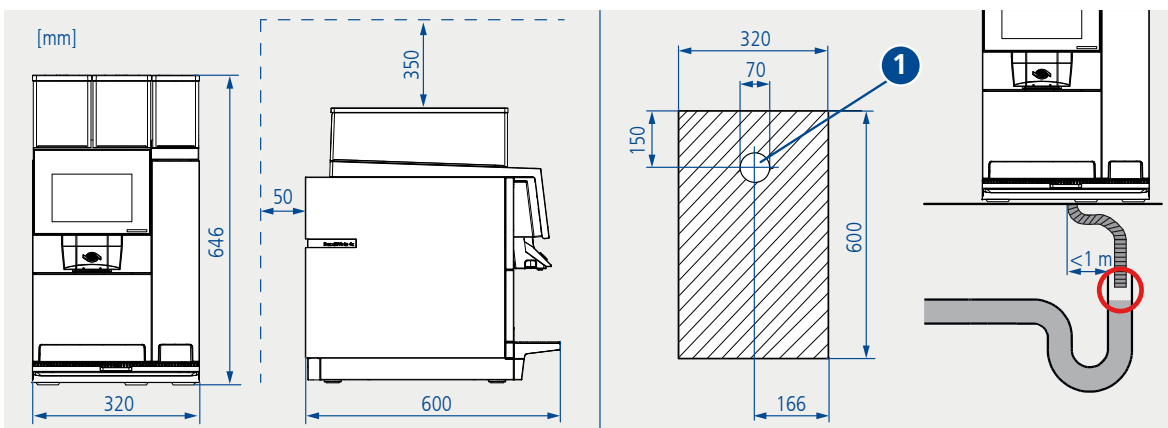

1 Hole diameter 70 mm for water-/milk inlet and water outlet. Also possible for electric cords.

Drainage

- Distance machine to drain < 1 m.
- No dip in the drain hose.
- No back pressure in the drain hose.
- End of the hose must not be in the water.

Milk suction tube refrigerator

- Max. length milk suction tube refrigerator = 1200 mm. Position the refrigerator close enough to the coffee machine.

Machine parameters		Water connection parameters		Milk connection parameters	
Connection	220-240 VAC 12-13 A 50/60 Hz	Water connection	3/8"	Length milk suction tube	1200 mm
Output	2700-3100 W	Water pressure	2-4 bar / 30-60 psi	Diameter milk suction tube	8.5/4 mm
Dimensions	320 x 600 x 646 mm (B / T / H)	Chlorine	None		
Coffee spout height	85-175 mm	TDS	70-200 ppm		
Weight	52 kg	Total hardness	5-8 °dH (8-14 °fH)		
		pH	6.8-7.4		
		Alkalinity	<100 ppm		
		Iron	<0.25 ppm		

Conversion table water hardness

Water hardness	German	French	English	Ppm	Mval/l
1° dH	1.0	1.79	1.25	17.8	0.357
1° fH	0.56	1.0	0.7	10.0	0.2
1° e	0.8	1.43	1.0	14.3	0.86
1° ppm	0.056	0.1	0.07	1.0	0.02
1 mval/l	2.8	5.0	3.5	50.0	1.0